

Micron TRUE Planetary® Gearheads

UltraTRUE™ 90

Helical Right Angle Gearheads

Ready for Immediate Delivery	
Precision	4 arc-minutes
Frame Sizes	60 mm, 75 mm, 90 mm, 100 mm, 115 mm, 142 mm and 180 mm
Torque Capacity	up to 3111 Nm
Ratio Availability	1:1 thru 50:1
Radial load capacity	up to 37910 N
Mounting System	RediMount™

- 1 Tapered roller bearings**
provide high axial and radial load carrying capacity
- 2 Helical crowned**
HRC 55-60 steel gears
provide higher torque capacity and smoother operation
- 3 PowerTRUE™ gear technology**
provides high torque capacity in a compact package
- 4 RediMount system**
provides error-free motor installation

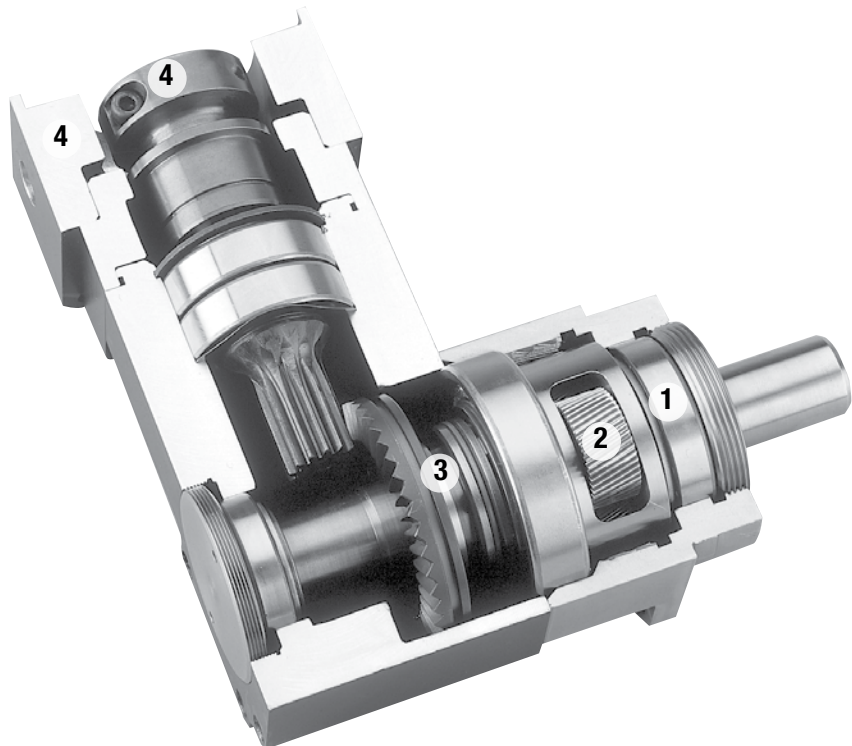

*Micron True Planetary® Gearheads
shipped within 24 hours!*



*Need it fast? Go to the back cover
of the catalog for details.*

Helical Right Angle Gearheads

Metric

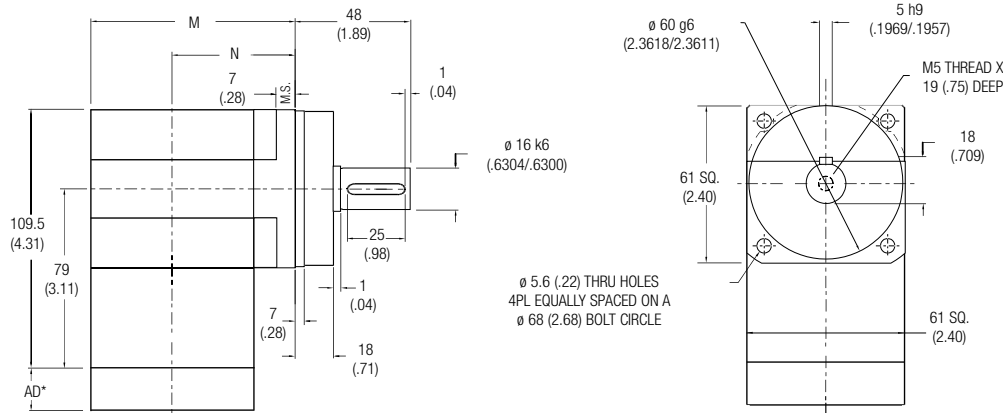

Ratio ¹	Dimension 'M' mm [in.]	Dimension 'N' mm [in.]	Backlash [arc-min]	Weight kg [lb.]	Efficiency
1:1 to 5:1	86 [3.38]	55 [2.18]	4 max	2,5 [5.5]	98%
8:1 to 50:1	95 [3.75]	65 [2.55]	5 max	3 [6.6]	93%

All dimensions are: mm (in.)
 AD** = Adapter length
 Adapter length will vary depending on motor.
 M.S.= Mounting Surface
 Efficiency is calculated at 100% of the rated torque.

Performance Specifications

Part Number	Ratio ¹	10,000 Hour Life			T _{peak} Nm [in.-lb.]	20,000 Hour Life			J kg-cm ² [in.-lb.-sec ² x10 ⁻⁴]	Torsional Stiffness Nm/arc-min [in.-lb./arc-min]
		T _r (1000 rpm) Nm [in.-lb.]	T _r (3000 rpm) Nm [in.-lb.]	T _r (5000 rpm) Nm [in.-lb.]		T _r (1000 rpm) Nm [in.-lb.]	T _r (3000 rpm) Nm [in.-lb.]	T _r (5000 rpm) Nm [in.-lb.]		
UTR006-001	1:1	9 [77]	8 [70]	7 [64]	28 [247]	8 [71]	7 [65]	7 [59]	.97 [8.4]	2,1 [19]
UTR006-002	2:1	19 [170]	17 [155]	16 [140]	52 [456]	18 [157]	16 [143]	15 [129]	.50 [4.3]	3,2 [29]
UTR006-003	3:1	12 [108]	11 [99]	10 [89]	39 [342]	11 [100]	10 [91]	9 [82]	.43 [3.7]	3,6 [32]
UTR006-004	4:1	9 [80]	8 [73]	7 [66]	34 [301]	8 [73]	8 [67]	7 [61]	.40 [3.4]	3,8 [34]
UTR006-005	5:1	7 [65]	7 [60]	6 [54]	26 [228]	7 [60]	6 [55]	6 [50]	.39 [3.4]	3,9 [35]
UTR006-008	8:1	51 [447]	47 [413]	45 [394]	106 [938]	49 [438]	45 [397]	38 [340]	.50 [4.4]	2,1 [18]
UTR006-010	10:1	49 [433]	45 [401]	43 [384]	102 [906]	48 [423]	44 [392]	40 [355]	.49 [4.4]	1,8 [16]
UTR006-012	12:1	49 [432]	45 [394]	40 [356]	109 [961]	45 [399]	41 [364]	37 [329]	.39 [3.5]	2,0 [18]
UTR006-014	14:1	46 [411]	43 [383]	42 [368]	97 [860]	45 [402]	42 [374]	41 [360]	.49 [4.4]	2,4 [22]
UTR006-015	15:1	50 [443]	47 [413]	45 [397]	105 [927]	49 [433]	46 [404]	44 [388]	.39 [3.4]	2,4 [21]
UTR006-016	16:1	36 [318]	33 [290]	30 [262]	110 [975]	33 [294]	30 [268]	27 [242]	.39 [3.5]	2,4 [22]
UTR006-020	20:1	45 [398]	41 [363]	37 [328]	106 [939]	41 [367]	38 [335]	34 [303]	.39 [3.5]	2,4 [21]
UTR006-025	25:1	37 [326]	34 [298]	30 [269]	107 [948]	34 [301]	31 [275]	28 [249]	.38 [3.4]	2,3 [21]
UTR006-028	28:1	48 [427]	45 [401]	44 [388]	100 [887]	47 [417]	44 [392]	43 [379]	.39 [3.5]	2,2 [20]
UTR006-030	30:1	30 [266]	26 [232]	25 [217]	93 [822]	28 [246]	24 [215]	23 [201]	.42 [3.7]	2,3 [20]
UTR006-035	35:1	49 [432]	46 [407]	43 [377]	101 [894]	48 [422]	44 [385]	39 [348]	.38 [3.4]	2,3 [20]
UTR006-040	40:1	31 [275]	27 [240]	25 [225]	94 [830]	29 [255]	25 [223]	24 [208]	.39 [3.5]	2,4 [22]
UTR006-050	50:1	32 [283]	28 [247]	26 [232]	94 [836]	30 [262]	26 [229]	24 [215]	.38 [3.4]	2,4 [21]

All ratios are available to ship in 24 hours through the Gearhead Express Program.

¹ Ratios are exact, higher ratios are also available, consult factory.
 T_r = Rated output torque at rated speed for specific hours of life.

T_{peak} = Allowable momentary peak torque for emergency stop or heavy shock loading.
 J = Mass moment of inertia reflected to the input shaft (including pinion assembly).

Micron TRUE Planetary® Gearheads

UltraTRUE™ 90 Size 75

Helical Right Angle Gearheads

Metric

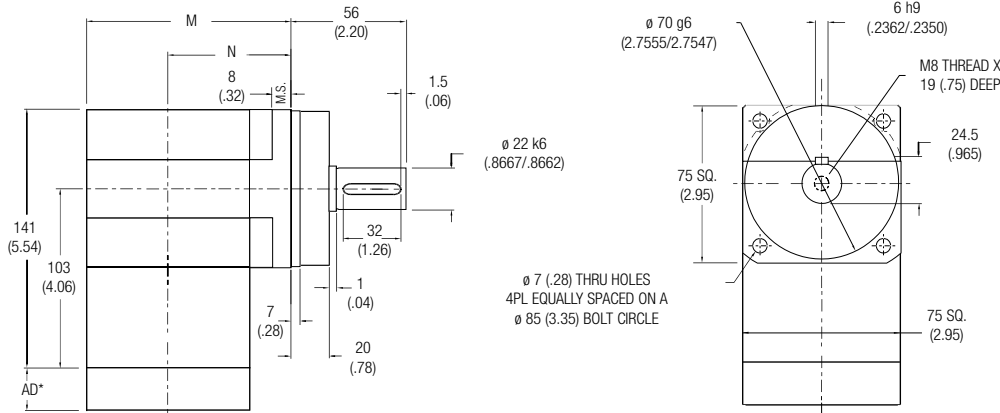

Ratio ¹	Dimension 'M' mm [in.]	Dimension 'N' mm [in.]	Backlash [arc-min]	Weight kg [lb.]	Efficiency
1:1 to 5:1	89 [3.51]	52 [2.04]	4 max	4.8 [10]	98%
8:1 to 50:1	114.5 [4.51]	77 [3.04]	5 max	5.3 [11.1]	93%

All dimensions are: mm (in.)
 AD** = Adapter length
 Adapter length will vary depending on motor.
 M.S. = Mounting Surface
 Efficiency is calculated at 100% of the rated torque.

Performance Specifications

Part Number	Ratio ¹	10,000 Hour Life				T peak Nm [in.-lb.]	20,000 Hour Life			J kg-cm ² [in.-lb.-sec ² x10 ⁻⁴]	Torsional Stiffness Nm/arc-min [in.-lb./arc-min]
		T _r (1000 rpm) Nm [in.-lb.]	T _r (3000 rpm) Nm [in.-lb.]	T _r (5000 rpm) Nm [in.-lb.]	T _r (1000 rpm) Nm [in.-lb.]		T _r (3000 rpm) Nm [in.-lb.]	T _r (5000 rpm) Nm [in.-lb.]			
UTR075-001	1:1	25 [220]	23 [200]	20 [181]	71 [625]	23 [203]	21 [185]	19 [167]	3,7 [33]	5,1 [46]	
UTR075-002	2:1	56 [498]	51 [455]	46 [411]	159 [1410]	52 [460]	47 [420]	43 [380]	1,9 [17]	7,7 [69]	
UTR075-003	3:1	37 [329]	34 [300]	31 [271]	129 [1146]	34 [304]	31 [277]	28 [250]	1,6 [15]	8,8 [78]	
UTR075-004	4:1	28 [252]	26 [230]	23 [208]	99 [880]	26 [232]	24 [212]	22 [192]	1,5 [13]	9,2 [81]	
UTR075-005	5:1	21 [185]	19 [169]	17 [153]	83 [735]	19 [171]	18 [156]	16 [141]	1,5 [13]	9,4 [83]	
UTR075-008	8:1	91 [802]	83 [737]	79 [702]	189 [1671]	89 [785]	81 [720]	78 [686]	1,9 [17]	4,7 [41]	
UTR075-010	10:1	88 [777]	81 [716]	77 [684]	183 [1617]	86 [759]	79 [700]	76 [669]	1,9 [17]	4,1 [36]	
UTR075-012	12:1	93 [824]	86 [762]	82 [730]	194 [1715]	91 [805]	84 [746]	81 [714]	1,5 [14]	4,6 [41]	
UTR075-014	14:1	83 [738]	77 [685]	74 [657]	174 [1536]	82 [722]	76 [670]	73 [643]	1,9 [17]	6,6 [58]	
UTR075-015	15:1	90 [796]	84 [740]	80 [710]	187 [1656]	88 [779]	82 [723]	78 [694]	1,5 [13]	6,7 [59]	
UTR075-016	16:1	95 [838]	88 [780]	85 [749]	197 [1743]	93 [820]	86 [762]	83 [732]	1,5 [14]	6,7 [59]	
UTR075-020	20:1	91 [810]	85 [756]	82 [727]	190 [1681]	89 [792]	83 [739]	80 [711]	1,5 [14]	6,5 [58]	
UTR075-025	25:1	93 [820]	87 [767]	84 [740]	192 [1698]	91 [801]	85 [750]	80 [705]	1,5 [13]	6,4 [57]	
UTR075-028	28:1	87 [768]	81 [720]	79 [695]	179 [1589]	85 [751]	80 [704]	77 [679]	1,5 [14]	5,9 [52]	
UTR075-030	30:1	54 [480]	47 [418]	44 [391]	166 [1473]	50 [444]	44 [387]	41 [361]	1,6 [15]	6,3 [56]	
UTR075-035	35:1	88 [776]	83 [730]	80 [706]	181 [1603]	86 [759]	81 [714]	78 [690]	1,5 [13]	6,3 [56]	
UTR075-040	40:1	56 [497]	49 [433]	46 [406]	168 [1489]	52 [460]	45 [401]	42 [375]	1,5 [14]	6,7 [59]	
UTR075-050	50:1	58 [510]	50 [446]	47 [418]	170 [1500]	53 [472]	47 [413]	44 [387]	1,5 [13]	6,6 [58]	

All ratios are available to ship in 24 hours through the Gearhead Express Program.

¹ Ratios are exact, higher ratios are also available, consult factory.
 T_r = Rated output torque at rated speed for specific hours of life.

T_{peak} = Allowable momentary peak torque for emergency stop or heavy shock loading.
 J = Mass moment of inertia reflected to the input shaft (including pinion assembly).

Helical Right Angle Gearheads

Metric

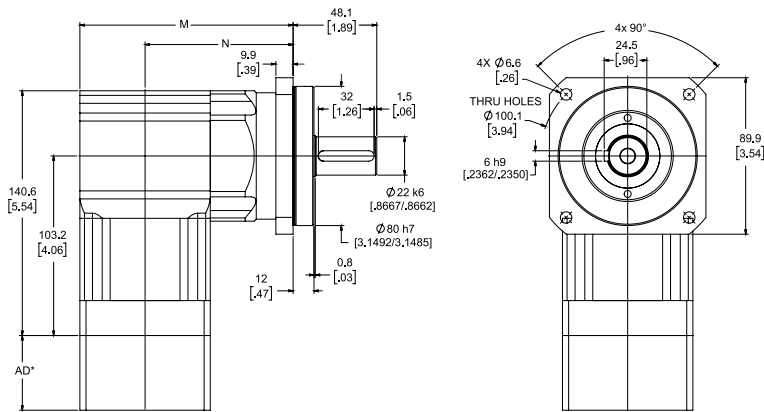

Ratio ¹	Dimension 'M' mm [in.]	Dimension 'N' mm [in.]	Backlash [arc-min]	Weight kg [lb.]	Efficiency
1:1 to 5:1	97 [3.82]	60 [2.35]	4 max	4.8 [10]	98%
8:1 to 50:1	122.5 [4.82]	85 [3.35]	5 max	5.3 [11.1]	93%

All dimensions are: mm (in.)

AD** = Adapter length

Adapter length will vary depending on motor.M.S.= Mounting Surface

Efficiency is calculated at 100% of the rated torque.

Performance Specifications

Part Number	Ratio ¹	10,000 Hour Life			T peak Nm [in.-lb.]	20,000 Hour Life			J kg-cm ² [in.-lb.-sec ² x10 ⁻⁴]	Torsional Stiffness Nm/arc-min [in.-lb./arc-min]
		T _r (1000 rpm) Nm [in.-lb.]	T _r (3000 rpm) Nm [in.-lb.]	T _r (5000 rpm) Nm [in.-lb.]		T _r (1000 rpm) Nm [in.-lb.]	T _r (3000 rpm) Nm [in.-lb.]	T _r (5000 rpm) Nm [in.-lb.]		
UTR090-001	1:1	25 [220]	23 [200]	20 [181]	71 [625]	23 [203]	21 [185]	19 [167]	3,7 [33]	5,1 [46]
UTR090-002	2:1	56 [498]	51 [455]	46 [411]	159 [1410]	52 [460]	47 [420]	43 [380]	1,9 [17]	7,7 [69]
UTR090-003	3:1	37 [329]	34 [300]	31 [271]	129 [1146]	34 [304]	31 [277]	28 [250]	1,6 [15]	8,8 [78]
UTR090-004	4:1	28 [252]	26 [230]	23 [208]	99 [880]	26 [232]	24 [212]	22 [192]	1,5 [13]	9,2 [81]
UTR090-005	5:1	21 [185]	19 [169]	17 [153]	83 [735]	19 [171]	18 [156]	16 [141]	1,5 [13]	9,4 [83]
UTR090-008	8:1	91 [802]	83 [737]	79 [702]	189 [1671]	89 [785]	81 [720]	78 [686]	1,9 [17]	4,7 [41]
UTR090-010	10:1	88 [777]	81 [716]	77 [684]	183 [1617]	86 [759]	79 [700]	76 [669]	1,9 [17]	4,1 [36]
UTR090-012	12:1	93 [824]	86 [762]	82 [730]	194 [1715]	91 [805]	84 [746]	81 [714]	1,5 [14]	4,6 [41]
UTR090-014	14:1	83 [738]	77 [685]	74 [657]	174 [1536]	82 [722]	76 [670]	73 [643]	1,9 [17]	6,6 [58]
UTR090-015	15:1	90 [796]	84 [740]	80 [710]	187 [1656]	88 [779]	82 [723]	78 [694]	1,5 [13]	6,7 [59]
UTR090-016	16:1	95 [838]	88 [780]	85 [749]	197 [1743]	93 [820]	86 [762]	83 [732]	1,5 [14]	6,7 [59]
UTR090-020	20:1	91 [810]	85 [756]	82 [727]	190 [1681]	89 [792]	83 [739]	80 [711]	1,5 [14]	6,5 [58]
UTR090-025	25:1	93 [820]	87 [767]	84 [740]	192 [1698]	91 [801]	85 [750]	80 [705]	1,5 [13]	6,4 [57]
UTR090-028	28:1	87 [768]	81 [720]	79 [695]	179 [1589]	85 [751]	80 [704]	77 [679]	1,5 [14]	5,9 [52]
UTR090-030	30:1	54 [480]	47 [418]	44 [391]	166 [1473]	50 [444]	44 [387]	41 [361]	1,6 [15]	6,3 [56]
UTR090-035	35:1	88 [776]	83 [730]	80 [706]	181 [1603]	86 [759]	81 [714]	78 [690]	1,5 [13]	6,3 [56]
UTR090-040	40:1	56 [497]	49 [433]	46 [406]	168 [1489]	52 [460]	45 [401]	42 [375]	1,5 [14]	6,7 [59]
UTR090-050	50:1	58 [510]	50 [446]	47 [418]	170 [1500]	53 [472]	47 [413]	44 [387]	1,5 [13]	6,6 [58]

All ratios are available to ship in 24 hours through the Gearhead Express Program.

¹ Ratios are exact, higher ratios are also available, consult factory.
T_r = Rated output torque at rated speed for specific hours of life.

T_{peak} = Allowable momentary peak torque for emergency stop or heavy shock loading.
J = Mass moment of inertia reflected to the input shaft (including pinion assembly).

Micron TRUE Planetary® Gearheads

UltraTRUE™ 90 Size 10

Helical Right Angle Gearheads

Metric

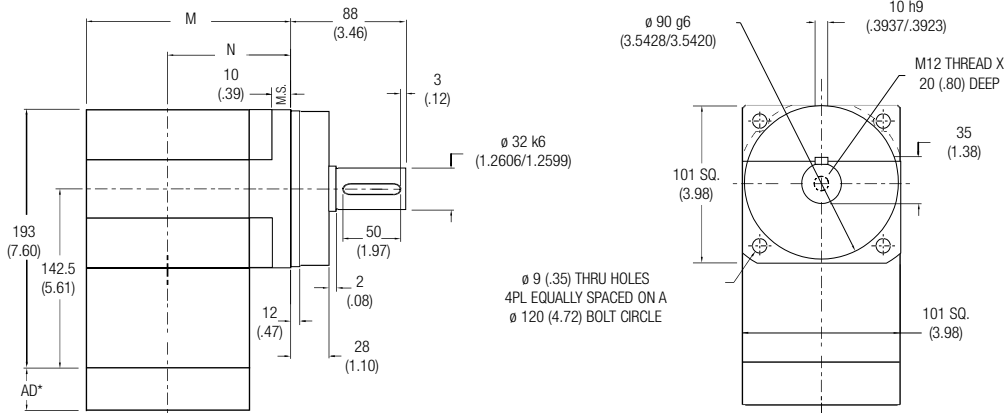

Ratio ¹	Dimension 'M' mm [in.]	Dimension 'N' mm [in.]	Backlash [arc-min]	Weight kg [lb.]	Efficiency
1:1 to 5:1	121 [4.75]	70 [2.76]	4 max	11 [24]	98%
8:1 to 50:1	149 [5.88]	99 [3.89]	5 max	12 [26.2]	93%

All dimensions are: mm (in.)
 AD** = Adapter length
 Adapter length will vary depending on motor.
 M.S. = Mounting Surface
 Efficiency is calculated at 100% of the rated torque.

Performance Specifications

Part Number	Ratio ¹	10,000 Hour Life				T peak Nm [in.-lb.]	20,000 Hour Life			J kg-cm ² [in.-lb.-sec ² x10 ⁻⁴]	Torsional Stiffness Nm/arc-min [in.-lb./arc-min]
		T _r (1000 rpm) Nm [in.-lb.]	T _r (3000 rpm) Nm [in.-lb.]	T _r (5000 rpm) Nm [in.-lb.]	T _r (1000 rpm) Nm [in.-lb.]		T _r (3000 rpm) Nm [in.-lb.]	T _r (5000 rpm) Nm [in.-lb.]			
UTR010-001	1:1	73 [648]	67 [591]	60 [535]	232 [2052]	68 [598]	62 [546]	56 [494]	6,3 [56]	9,2 [81]	
UTR010-002	2:1	131 [1157]	119 [1056]	108 [955]	323 [2856]	121 [1068]	110 [975]	100 [882]	3,2 [29]	15,0 [133]	
UTR010-003	3:1	101 [898]	93 [820]	84 [741]	292 [2582]	94 [830]	86 [757]	77 [684]	2,8 [25]	17,1 [151]	
UTR010-004	4:1	68 [598]	62 [546]	56 [494]	227 [2006]	62 [552]	57 [504]	51 [456]	2,6 [23]	17,9 [159]	
UTR010-005	5:1	51 [449]	46 [409]	42 [370]	187 [1653]	47 [414]	43 [378]	39 [342]	2,5 [23]	18,3 [162]	
UTR010-008	8:1	266 [2358]	243 [2147]	229 [2031]	547 [4844]	260 [2305]	217 [1923]	186 [1650]	3,3 [29]	16,6 [147]	
UTR010-010	10:1	258 [2286]	236 [2092]	225 [1989]	531 [4701]	253 [2235]	226 [2005]	194 [1720]	3,3 [29]	13,1 [116]	
UTR010-012	12:1	274 [2426]	252 [2229]	240 [2125]	564 [4992]	270 [2389]	245 [2171]	210 [1863]	2,6 [23]	18,8 [167]	
UTR010-014	14:1	246 [2178]	227 [2007]	217 [1917]	506 [4481]	241 [2129]	222 [1963]	207 [1834]	3,3 [29]	23,1 [204]	
UTR010-015	15:1	265 [2349]	245 [2168]	234 [2072]	546 [4832]	259 [2297]	240 [2120]	219 [1943]	2,5 [23]	24,3 [215]	
UTR010-016	16:1	270 [2393]	247 [2184]	223 [1975]	575 [5085]	250 [2210]	228 [2016]	206 [1823]	2,6 [23]	24,8 [220]	
UTR010-020	20:1	270 [2391]	251 [2219]	240 [2127]	555 [4916]	264 [2338]	245 [2170]	235 [2080]	2,6 [23]	22,1 [196]	
UTR010-025	25:1	253 [2243]	231 [2047]	209 [1851]	562 [4974]	234 [2072]	214 [1890]	193 [1709]	2,5 [23]	22,1 [196]	
UTR010-028	28:1	256 [2270]	239 [2119]	230 [2038]	526 [4659]	251 [2220]	234 [2072]	225 [1993]	2,6 [23]	19,2 [170]	
UTR010-030	30:1	159 [1405]	138 [1220]	129 [1139]	488 [4317]	147 [1300]	128 [1129]	119 [1054]	2,8 [25]	19,1 [169]	
UTR010-035	35:1	260 [2298]	243 [2152]	234 [2074]	532 [4707]	254 [2248]	238 [2104]	229 [2028]	2,5 [23]	19,0 [168]	
UTR010-040	40:1	164 [1456]	143 [1267]	134 [1184]	494 [4372]	152 [1347]	132 [1173]	124 [1096]	2,6 [23]	24,9 [221]	
UTR010-050	50:1	169 [1496]	147 [1304]	138 [1220]	498 [4410]	156 [1384]	136 [1207]	128 [1129]	2,5 [23]	21,9 [194]	

All ratios are available to ship in 24 hours through the Gearhead Express Program.

¹ Ratios are exact, higher ratios are also available, consult factory.
 T_r = Rated output torque at rated speed for specific hours of life.

T_{peak} = Allowable momentary peak torque for emergency stop or heavy shock loading.
 J = Mass moment of inertia reflected to the input shaft (including pinion assembly).

Helical Right Angle Gearheads

Metric

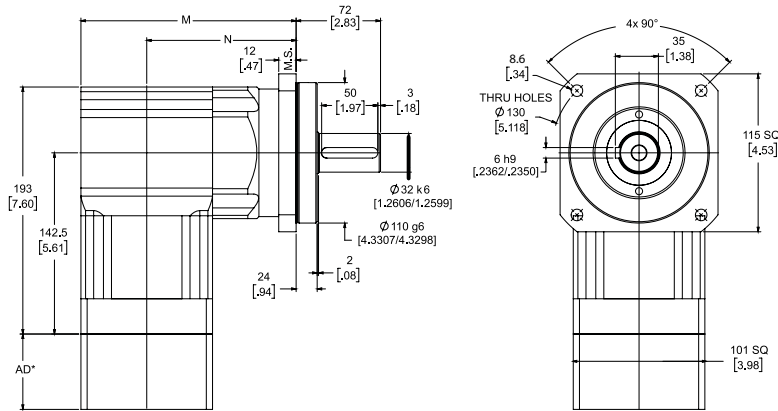

Ratio ¹	Dimension 'M' mm [in.]	Dimension 'N' mm [in.]	Backlash [arc-min]	Weight kg [lb.]	Efficiency
1:1 to 5:1	136,7 [5.38]	86 [3.39]	4 max	11 [24]	98%
8:1 to 50:1	165 [6.51]	114,8 [4.52]	5 max	12 [26.2]	93%

All dimensions are: mm (in.)

AD** = Adapter length

Adapter length will vary depending on motor.

M.S. = Mounting Surface

Efficiency is calculated at 100% of the rated torque.

Performance Specifications

Part Number	Ratio ¹	10,000 Hour Life			T _{peak} Nm [in.-lb.]	20,000 Hour Life			J kg-cm ² [in.-lb.-sec ² x10 ⁻⁴]	Torsional Stiffness Nm/arc-min [in.-lb./arc-min]
		T _r (1000 rpm) Nm [in.-lb.]	T _r (3000 rpm) Nm [in.-lb.]	T _r (5000 rpm) Nm [in.-lb.]		T _r (1000 rpm) Nm [in.-lb.]	T _r (3000 rpm) Nm [in.-lb.]	T _r (5000 rpm) Nm [in.-lb.]		
UTR115-001	1:1	73 [648]	67 [591]	60 [535]	232 [2052]	68 [598]	62 [546]	56 [494]	6,3 [56]	9,2 [81]
UTR115-002	2:1	131 [1157]	119 [1056]	108 [955]	323 [2856]	121 [1068]	110 [975]	100 [882]	3,2 [29]	15,0 [133]
UTR115-003	3:1	101 [898]	93 [820]	84 [741]	292 [2582]	94 [830]	86 [757]	77 [684]	2,8 [25]	17,1 [151]
UTR115-004P	4:1	68 [598]	62 [546]	56 [494]	227 [2006]	62 [552]	57 [504]	51 [456]	2,6 [23]	17,9 [159]
UTR115-005P	5:1	51 [449]	46 [409]	42 [370]	187 [1653]	47 [414]	43 [378]	39 [342]	2,5 [23]	18,3 [162]
UTR115-008	8:1	266 [2358]	243 [2147]	229 [2031]	547 [4844]	260 [2305]	217 [1923]	186 [1650]	3,3 [29]	16,6 [147]
UTR115-010	10:1	258 [2286]	236 [2092]	225 [1989]	531 [4701]	253 [2235]	226 [2005]	194 [1720]	3,3 [29]	13,1 [116]
UTR115-012	12:1	274 [2426]	252 [2229]	240 [2125]	564 [4992]	270 [2389]	245 [2171]	210 [1863]	2,6 [23]	18,8 [167]
UTR115-014	14:1	246 [2178]	227 [2007]	217 [1917]	506 [4481]	241 [2129]	222 [1963]	207 [1834]	3,3 [29]	23,1 [204]
UTR115-015	15:1	265 [2349]	245 [2168]	234 [2072]	546 [4832]	259 [2297]	240 [2120]	219 [1943]	2,5 [23]	24,3 [215]
UTR115-016	16:1	270 [2393]	247 [2184]	223 [1975]	575 [5085]	250 [2210]	228 [2016]	206 [1823]	2,6 [23]	24,8 [220]
UTR115-020	20:1	270 [2391]	251 [2219]	240 [2127]	555 [4916]	264 [2338]	245 [2170]	235 [2080]	2,6 [23]	22,1 [196]
UTR115-025	25:1	253 [2243]	231 [2047]	209 [1851]	562 [4974]	234 [2072]	214 [1890]	193 [1709]	2,5 [23]	22,1 [196]
UTR115-028	28:1	256 [2270]	239 [2119]	230 [2038]	526 [4659]	251 [2220]	234 [2072]	225 [1993]	2,6 [23]	19,2 [170]
UTR115-030	30:1	159 [1405]	138 [1220]	129 [1139]	488 [4317]	147 [1300]	128 [1129]	119 [1054]	2,8 [25]	19,1 [169]
UTR115-035	35:1	260 [2298]	243 [2152]	234 [2074]	532 [4707]	254 [2248]	238 [2104]	229 [2028]	2,5 [23]	19,0 [168]
UTR115-040	40:1	164 [1456]	143 [1267]	134 [1184]	494 [4372]	152 [1347]	132 [1173]	124 [1096]	2,6 [23]	24,9 [221]
UTR115-050	50:1	169 [1496]	147 [1304]	138 [1220]	498 [4410]	156 [1384]	136 [1207]	128 [1129]	2,5 [23]	21,9 [194]

All ratios are available to ship in 24 hours through the Gearhead Express Program.

¹ Ratios are exact, higher ratios are also available, consult factory.
T_r = Rated output torque at rated speed for specific hours of life.

T_{peak} = Allowable momentary peak torque for emergency stop or heavy shock loading.
J = Mass moment of inertia reflected to the input shaft (including pinion assembly).

Micron TRUE Planetary® Gearheads

UltraTRUE™ 90 Size 14

Helical Right Angle Gearheads

Metric

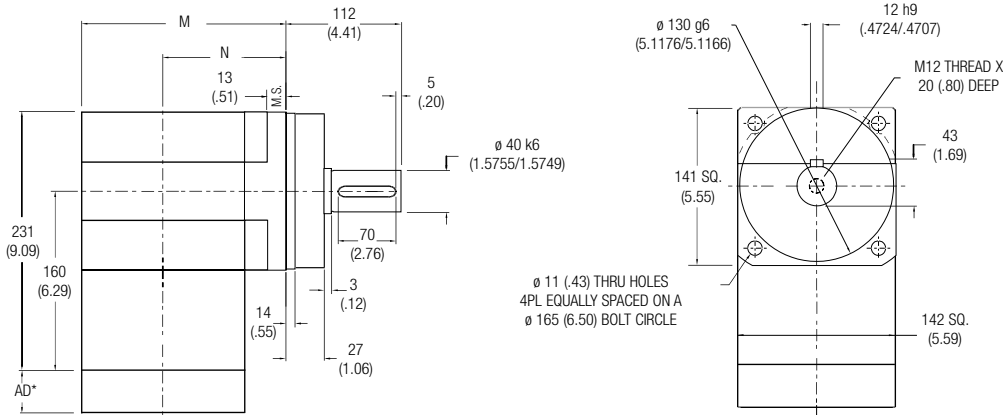

Ratio ¹	Dimension 'M' mm [in.]	Dimension 'N' mm [in.]	Backlash [arc-min]	Weight kg [lb.]	Efficiency
1:1 to 5:1P	166 [6.54]	95 [3.74]	4 max	24 [53]	98%
8:1 to 50:1	222 [8.74]	151 [5.95]	5 max	29 [64]	93%

All dimensions are: mm (in.)
 AD** = Adapter length
 Adapter length will vary depending on motor.
 M.S. = Mounting Surface
 Efficiency is calculated at 100% of the rated torque.

Performance Specifications

Part Number	Ratio ¹	10,000 Hour Life			T peak Nm [in.-lb.]	20,000 Hour Life			J kg-cm ² [in.-lb.-sec ² x10 ⁻⁴]	Torsional Stiffness Nm/arc-min [in.-lb./arc-min]
		T _r (1000 rpm) Nm [in.-lb.]	T _r (3000 rpm) Nm [in.-lb.]	T _r (5000 rpm) Nm [in.-lb.]		T _r (1000 rpm) Nm [in.-lb.]	T _r (3000 rpm) Nm [in.-lb.]	T _r (5000 rpm) Nm [in.-lb.]		
UTR014-001	1:1	158 [1396]	144 [1274]	130 [1152]	380 [3363]	146 [1289]	133 [1177]	120 [1064]	32 [279]	28,4 [252]
UTR014-002	2:1	327 [2893]	298 [2640]	270 [2387]	708 [6270]	302 [2671]	275 [2438]	249 [2204]	16 [143]	46,6 [413]
UTR014-003	3:1	220 [1944]	201 [1774]	181 [1604]	545 [4822]	203 [1796]	185 [1639]	167 [1481]	14 [123]	52,9 [468]
UTR014-004P	4:1	158 [1396]	144 [1274]	130 [1152]	471 [4172]	146 [1289]	133 [1177]	120 [1064]	13 [114]	55,5 [491]
UTR014-005P	5:1	118 [1047]	108 [956]	98 [864]	396 [3506]	109 [967]	100 [883]	90 [798]	13 [112]	56,8 [503]
UTR014-008	8:1	625 [5531]	565 [5000]	533 [4719]	1269 [11,233]	611 [5408]	530 [4688]	454 [4022]	16 [146]	36,7 [325]
UTR014-010	10:1	606 [5364]	551 [4876]	522 [4617]	1233 [10,911]	593 [5245]	539 [4768]	474 [4192]	16 [145]	31,9 [282]
UTR014-012	12:1	644 [5702]	588 [5207]	559 [4944]	1313 [11,616]	630 [5576]	575 [5092]	513 [4542]	13 [116]	22,1 [195]
UTR014-014	14:1	578 [5118]	530 [4690]	504 [4461]	1179 [10,430]	565 [5005]	518 [4586]	493 [4363]	16 [145]	51,6 [457]
UTR014-015	15:1	624 [5522]	572 [5067]	545 [4824]	1272 [11,253]	610 [5399]	560 [4955]	533 [4717]	12 [113]	51,7 [457]
UTR014-016	16:1	631 [5587]	576 [5099]	521 [4610]	1340 [11,860]	583 [5160]	532 [4708]	481 [4257]	13 [115]	52,8 [467]
UTR014-020	20:1	636 [5627]	587 [5194]	561 [4963]	1296 [11,471]	622 [5503]	574 [5079]	548 [4854]	13 [115]	49,2 [435]
UTR014-025	25:1	592 [5240]	540 [4782]	488 [4324]	1314 [11,625]	547 [4839]	499 [4415]	451 [3992]	12 [113]	49,2 [435]
UTR014-028	28:1	605 [5350]	561 [4969]	539 [4767]	1231 [10,896]	591 [5232]	549 [4859]	527 [4661]	13 [115]	42,8 [379]
UTR014-030	30:1	380 [3363]	329 [2914]	307 [2715]	1143 [10,111]	352 [3112]	305 [2696]	284 [2512]	14 [124]	44,7 [396]
UTR014-035	35:1	612 [5420]	571 [5052]	549 [4857]	1246 [11,024]	599 [5300]	558 [4941]	537 [4750]	12 [113]	40,2 [356]
UTR014-040	40:1	394 [3486]	342 [3028]	319 [2826]	1159 [10,257]	364 [3226]	317 [2802]	295 [2615]	13 [115]	52,6 [466]
UTR014-050	50:1	405 [3584]	352 [3118]	329 [2914]	1171 [10,360]	375 [3316]	326 [2886]	305 [2696]	12 [112]	49,2 [435]

All ratios are available to ship in 24 hours through the Gearhead Express Program.

¹ Ratios are exact, higher ratios are also available, consult factory.
 T_r = Rated output torque at rated speed for specific hours of life.

T_{peak} = Allowable momentary peak torque for emergency stop or heavy shock loading.
 J = Mass moment of inertia reflected to the input shaft (including pinion assembly).

Helical Right Angle Gearheads

Metric

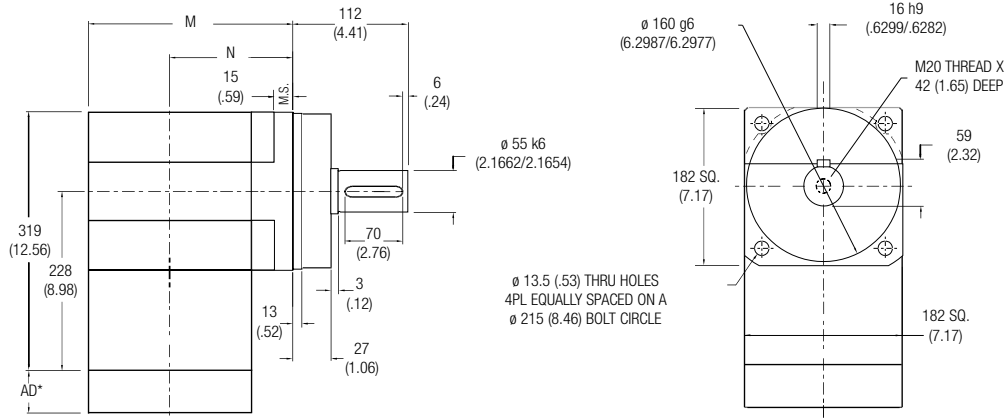

Ratio ¹	Dimension 'M' mm [in.]	Dimension 'N' mm [in.]	Backlash [arc-min]	Weight kg [lb.]	Efficiency
1:1 to 5:1	219 [8.64]	128 [5.05]	4 max	43 [96]	98%
8:1 to 50:1	273 [10.76]	182 [7.18]	5 max	48 [106]	93%

All dimensions are: mm (in.)
 AD** = Adapter length
 Adapter length will vary depending on motor.
 M.S. = Mounting Surface
 Efficiency is calculated at 100% of the rated torque.

Performance Specifications

Part Number	Ratio ¹	10,000 Hour Life			T _{peak} Nm [in.-lb.]	20,000 Hour Life			J kg-cm ² [in.-lb.-sec ² x10 ⁻⁴]	Torsional Stiffness Nm/arc-min [in.-lb./arc-min]
		T _r (1000 rpm) Nm [in.-lb.]	T _r (3000 rpm) Nm [in.-lb.]	T _r (5000 rpm) Nm [in.-lb.]		T _r (1000 rpm) Nm [in.-lb.]	T _r (3000 rpm) Nm [in.-lb.]	T _r (5000 rpm) Nm [in.-lb.]		
UTR018-001	1:1	248 [2195]	226 [2003]	205 [1811]	819 [7246]	229 [2027]	209 [1850]	189 [1672]	111 [985]	50 [440]
UTR018-002	2:1	654 [5786]	597 [5280]	539 [4774]	1911 [16914]	604 [5343]	551 [4876]	498 [4408]	57 [505]	82 [722]
UTR018-003	3:1	507 [4489]	463 [4096]	419 [3704]	1674 [14817]	468 [4145]	427 [3783]	386 [3420]	49 [434]	93 [820]
UTR018-004P	4:1	361 [3192]	329 [2913]	298 [2633]	1190 [10536]	333 [2947]	304 [2690]	275 [2432]	46 [403]	97 [860]
UTR018-005P	5:1	254 [2245]	231 [2048]	209 [1852]	837 [7410]	234 [2073]	214 [1892]	193 [1710]	45 [396]	99 [880]
UTR018-008	8:1	1460 [12920]	1309 [11589]	1230 [10888]	2929 [25920]	1428 [12634]	1184 [10476]	1016 [8988]	45 [401]	113 [998]
UTR018-010	10:1	1418 [12547]	1279 [11322]	1206 [10673]	2851 [25228]	1386 [12269]	1234 [10918]	1058 [9366]	45 [398]	92 [812]
UTR018-012	12:1	1509 [13352]	1368 [12108]	1294 [11448]	3040 [26900]	1475 [13057]	1337 [11832]	1147 [10150]	36 [317]	63 [560]
UTR018-014	14:1	1355 [11993]	1234 [10917]	1169 [10344]	2733 [24185]	1325 [11728]	1206 [10675]	1129 [9989]	45 [398]	111 [986]
UTR018-015	15:1	1463 [12944]	1333 [11800]	1265 [11192]	2950 [26109]	1430 [12657]	1304 [11539]	1195 [10578]	35 [310]	144 [1272]
UTR018-016	16:1	1443 [12769]	1317 [11652]	1191 [10536]	3111 [27532]	1332 [11791]	1216 [10760]	1099 [9729]	36 [316]	147 [1299]
UTR018-020	20:1	1493 [13209]	1370 [12121]	1304 [11541]	3014 [26674]	1460 [12917]	1339 [11853]	1275 [11285]	36 [316]	142 [1257]
UTR018-025	25:1	1268 [11226]	1158 [10245]	1047 [9263]	3060 [27078]	1171 [10366]	1069 [9460]	967 [8554]	35 [309]	119 [1055]
UTR018-028	28:1	1421 [12576]	1313 [11620]	1255 [11110]	2870 [25400]	1390 [12298]	1284 [11362]	1228 [10864]	36 [316]	126 [1113]
UTR018-030	30:1	897 [7935]	775 [6856]	721 [6377]	2665 [23583]	830 [7342]	717 [6344]	667 [5900]	38 [339]	113 [997]
UTR018-035	35:1	1441 [12750]	1337 [11828]	1281 [11338]	2908 [25736]	1409 [12468]	1307 [11567]	1253 [11087]	35 [309]	113 [998]
UTR018-040	40:1	930 [8231]	806 [7131]	751 [6645]	2708 [23967]	861 [7616]	746 [6599]	695 [6149]	36 [314]	147 [1299]
UTR018-050	50:1	956 [8465]	830 [7348]	775 [6856]	2739 [24239]	885 [7832]	768 [6799]	717 [6344]	35 [308]	142 [1257]

¹ Ratios are exact, higher ratios are also available, consult factory.
 T_r = Rated output torque at rated speed for specific hours of life.

T_{peak} = Allowable momentary peak torque for emergency stop or heavy shock loading.
 J = Mass moment of inertia reflected to the input shaft (including pinion assembly).

Micron TRUE Planetary® Gearheads

Radial and Axial Load Ratings

Ratios 1:1 thru 5:1 only

UTR006

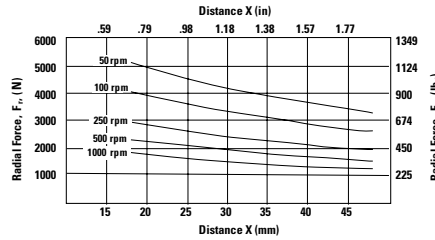
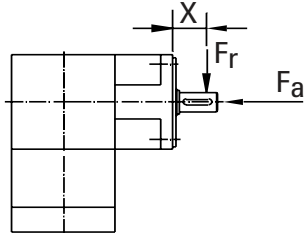

Speed rpm	Axial Load, F_a N [lb _f]
50	6543 [1471]
100	5191 [1167]
250	3825 [860]
500	3038 [683]
1000	2411 [542]

UTR075 and UTR090

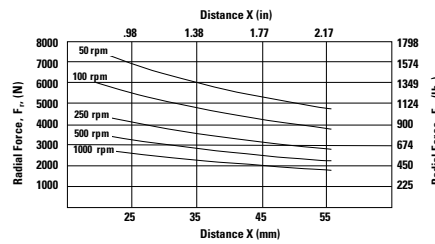
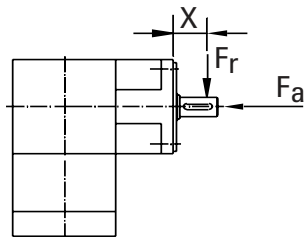

Speed rpm	Axial Load, F_a N [lb _f]
50	9003 [2024]
100	7148 [1607]
250	5266 [1184]
500	4181 [940]
1000	3318 [746]

UTR010 and UTR115

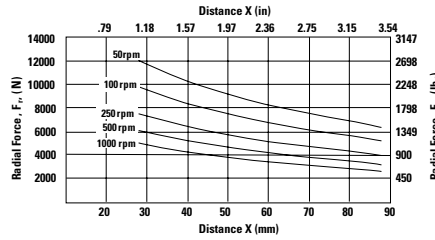
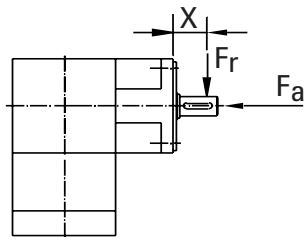

Speed rpm	Axial Load, F_a N [lb _f]
50	12,432 [2795]
100	10,097 [2270]
250	7668 [1724]
500	6232 [1401]
1000	5062 [1138]

UTR014

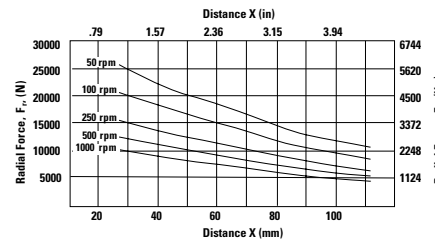
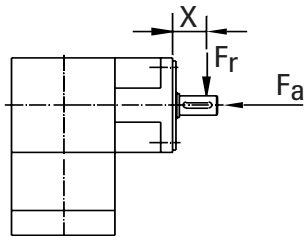

Speed rpm	Axial Load, F_a N [lb _f]
50	23,067 [5186]
100	18,735 [4212]
250	14,234 [3200]
500	11,560 [2599]
1000	9390 [2111]

UTR018

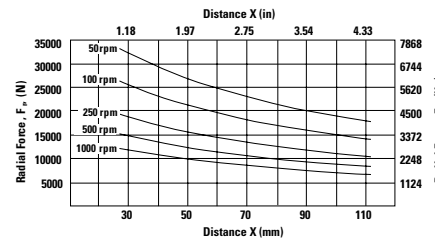
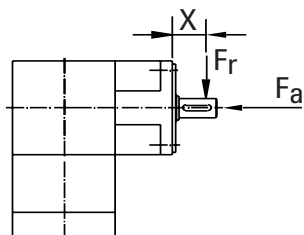

Speed rpm	Axial Load, F_a N [lb _f]
50	31,398 [7059]
100	24,922 [5603]
250	18,361 [4128]
500	14,576 [3277]
1000	11,569 [2601]

These graphs display the allowable radial load at a given distance (X) from the mounting surface based on an L_{10} life of 10,000 hours for the mean output speed n_{mout} , as described on page 9.

Radial and Axial Load Ratings

Ratios 8:1 thru 50:1 only

UTR006

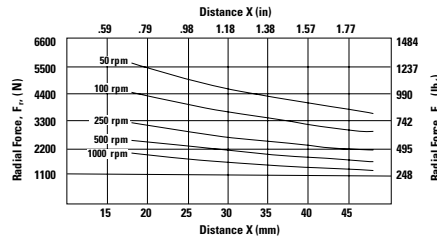
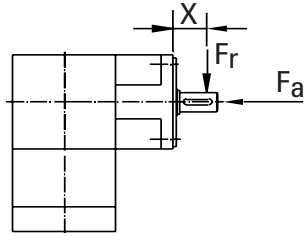

Speed rpm	Axial Load, F_a N [lb _f]
50	7198 [1618]
100	5710 [1284]
250	4208 [946]
500	3342 [751]
1000	2652 [596]

UTR075 and UTR090

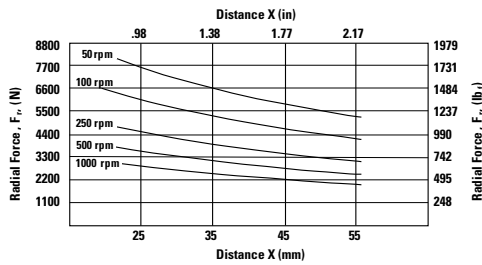
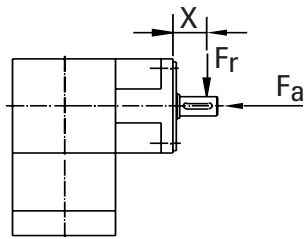

Speed rpm	Axial Load, F_a N [lb _f]
50	9903 [2227]
100	7863 [1768]
250	5793 [1303]
500	4599 [1034]
1000	3650 [821]

UTR010 and UTR115

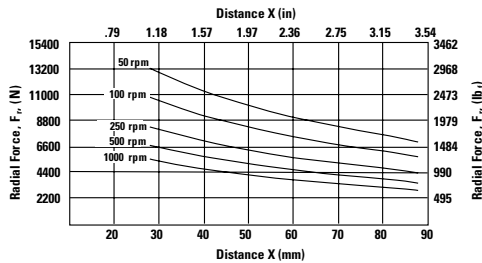
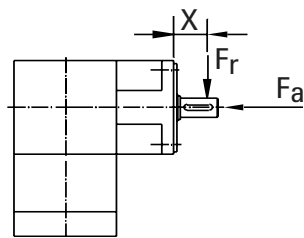

Speed rpm	Axial Load, F_a N [lb _f]
50	13,675 [3075]
100	11,107 [2497]
250	8435 [1897]
500	6855 [1542]
1000	5568 [1252]

UTR014

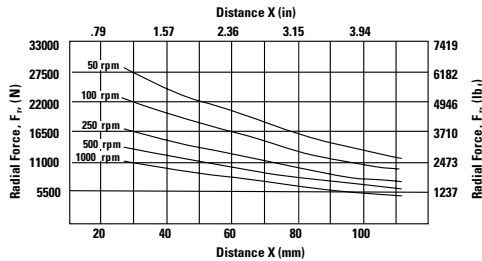
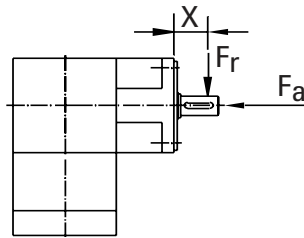

Speed rpm	Axial Load, F_a N [lb _f]
50	25,374 [5705]
100	20,609 [4633]
250	15,657 [3520]
500	12,716 [2859]
1000	10,329 [2322]

UTR018

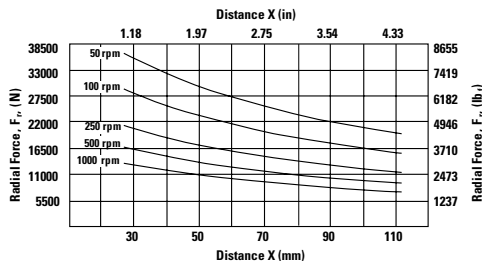
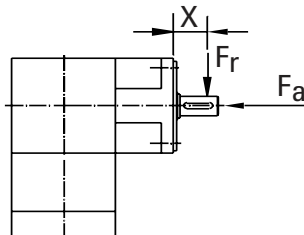

Speed rpm	Axial Load, F_a N [lb _f]
50	34,538 [7765]
100	27,414 [6163]
250	20,197 [4541]
500	16,034 [3605]
1000	12,726 [2861]

These graphs display the allowable radial load at a given distance (X) from the mounting surface based on an L₁₀ life of 10,000 hours for the mean output speed n_{mout} , as described on page 9.